

UVIREXTM 36

Wastewater Disinfectors

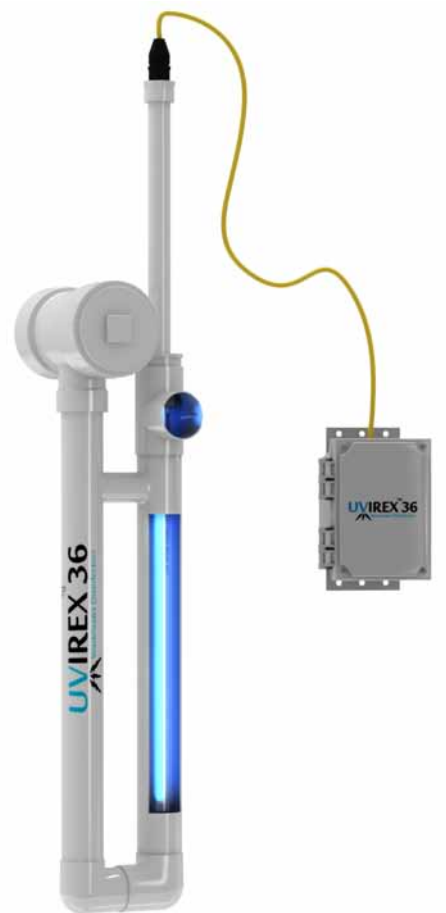

UVIREX 36: Ultraviolet Nanowave Disinfection for Small Flow Wastewater *Eliminates the Need for Chemicals Involved in Wastewater Treatment*

Simple, Affordable & Highly Effective

About UVIREX

UVIREX was developed by long established wastewater manufacturer and contract operator Winelco Inc. after the company was unable to find an affordable yet effective UV disinfection solution for its customers. After years of field research and development with the support of health department and EPA regulators, the resulting product is easy to install, simple and affordable to operate, and a more effective solution than other UV treatment offerings on the market. All products are backed by a one year warranty.

About UVIREX 36

Application

UVIREX 36 is designed for the on-site and decentralized wastewater treatment industry market and handles flows up to 8 gpm or 11,500 gpd. These systems are generally used for single family households or small businesses.

Technology

The UVIREX 36 disinfects treated wastewater through exposure to germicidal ultraviolet radiation at a wavelength of 253.7 nm emitted by a standard 36 watt T5 low-pressure Hg lamp. The process is enhanced by restricting flow to a minimal distance from the UV lamp, radically increasing UV intensity. The irradiation zone of the unit is covered with a UV reflective coating, which enhances exposure from multiple paths, an advantage in disinfection of particulate solids which could otherwise occlude germicidal rays. An extended 1" PVC pipe "Easy Grip" handle is attached for retrieval of the lamp and quartz sleeve from deep sumps, when service is required. The control enclosure is NEMA 4X immersion-rated. It displays a green LED "Power On" indicator, and is equipped to send a "Lamp Failure" signal to an external alarm. UVIREX 36 uses quartz in place of UV-restricting teflon & silicone, and does not experience the fouling and tearing associated with the material. Additionally the power connection at the UV lamp are designed to keep free of moisture, thus solving another operational failure in competitive units.

Regulatory Approval

UVIREX 36 is approved by the Ohio Department of Health as an Approved Pretreatment Component. It can also be used to retrofit existing UV treatment components pending approval by system manufacturers. Outside of Ohio, state and local regulations vary. Contact UVIREX for assistance with approval.

Installation Requirements

The UVIREX 36 is designed to conveniently mount on the end of a 4" PVC inlet pipe. The inlet tee may be a 4"x 2" side-outlet tee with a 4" cleanout cap in-place to direct flow through the disinfection chamber; or the inlet tee may be a 2" standard tee with a 4" x 2" reducer inserted into the 2" side outlet.

Operation Requirements

UVIREX is designed for ease of operation and minimal ongoing maintenance / repair costs. Lamp and Desiccant Pack should be replaced and the quartz sleeve cleaned once a year. The process takes approximately 10 - 20 minutes.



UVIREX 36: Ultraviolet Nanowave Disinfection for Small Flow Wastewater

Eliminates the Need for Chemicals Involved in Wastewater Treatment

Simple, Affordable & Highly Effective

Product Features

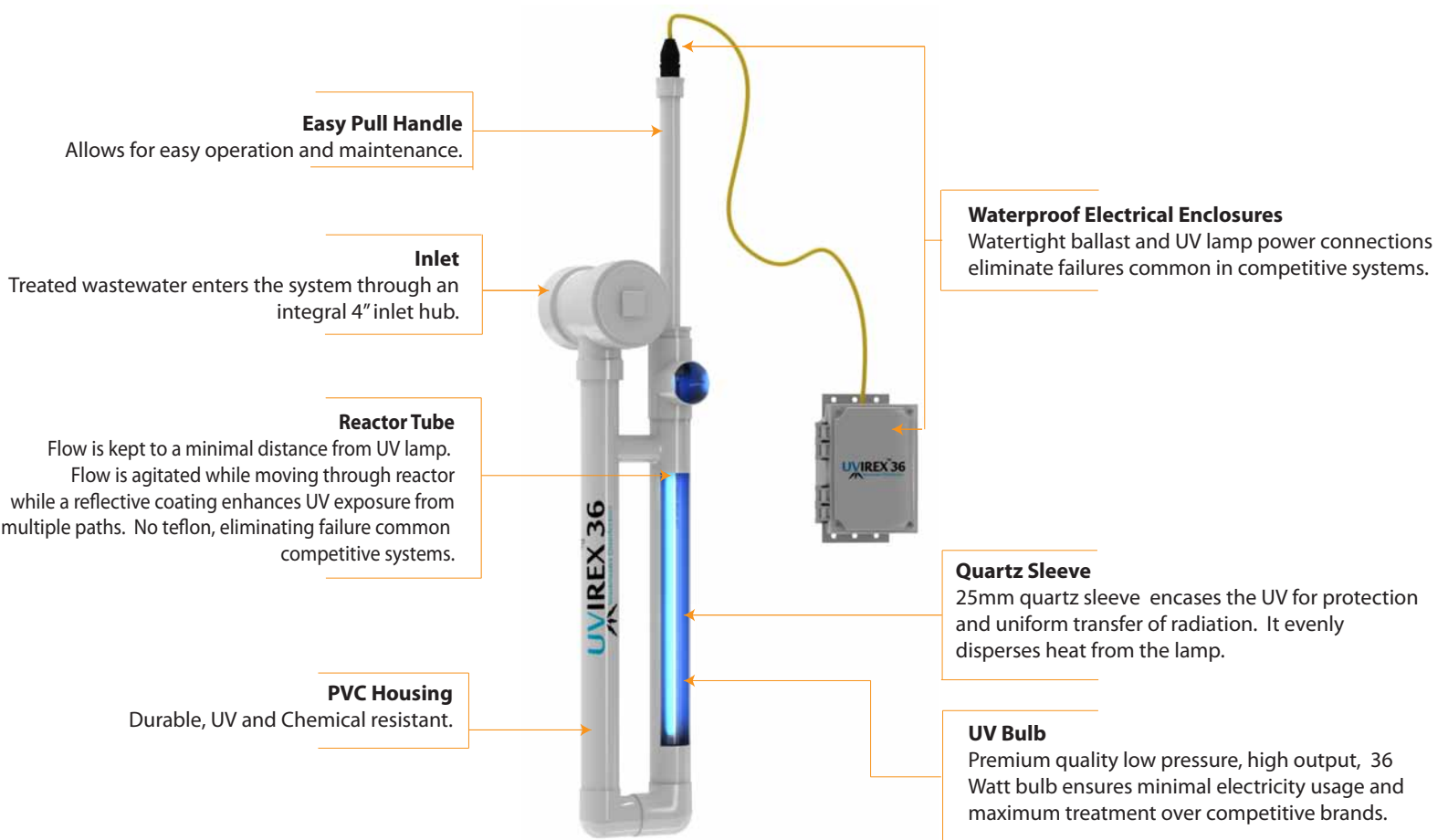

UVIREX 36 Specifications

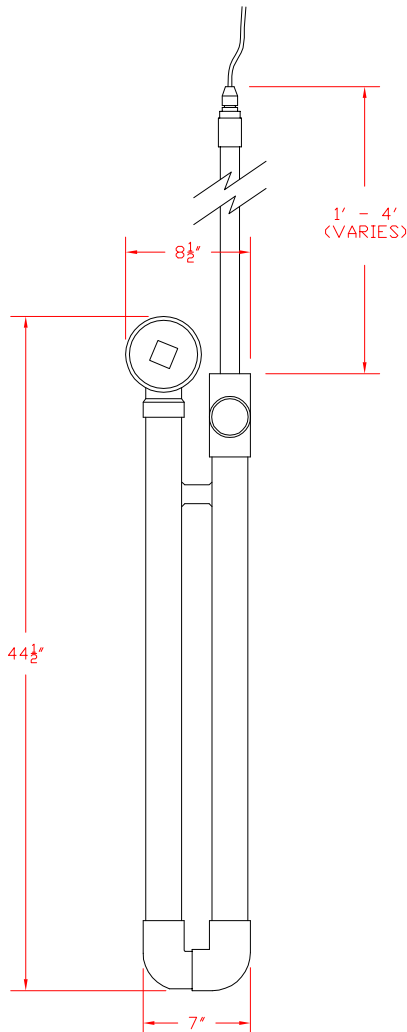

UVIREX SPECIFICATION	UVIREX Model 36
Maximum Flow Capacity	11,500 gpd 8 gpm
Total Wattage	36 Watts
Power Supply	120 Volts
Circuit Protection	Ground Fault Circuit Interrupter
Ballast	In Weatherproof Enclosure
Alarm	Available. Integrates with existing telemetry systems
Lamp	36 Watt, low pressure, 76 cm arc
UV Wavelength	253.7nm wavelength output
Output Depreciation	@ 9,000 hrs: 20%
Lamp Enclosure	25mm O.D. quartz tube
Reactor	2" reflective, agitating reactor tube
Reactor volume	.3 gal
UV Exposure	2.3 seconds at max flow rate
UV Dosage @ Maximum Flow	55,000uW sec./cm ² , (55 joules)
Dimensions	9" x 8.5" x 44.5"
Inlet / Outlet	4" / 2" , or customized
Warrants	1 year parts.

Contact Information

Winelco Inc.
6141 Centre Park Drive
West Chester, OH 45069
Phone: 1 (513) 755-8050
Fax: 1 (513) 755-8029

support@uvirex.com